

F11572

Mowbray Floor Fixing Kit

⚠ General Safety Warning ⚠

Please make sure that you read and follow these instructions carefully. Keep these instructions in a safe place for future reference.

1. INTENDED USE

The Mowbray floor fixing kit has been designed to offer additional support and stability for use with the Mowbray toilet frame range: M66613, M92740, N36974, M66625, N53909, M92739, M11089 & M48805.

2. SAFETY

WARNING: Do not exceed the maximum user weight for the toilet frame you are using with this product.

It is recommended that a suitably qualified, competent person installs this product.

Always check for concealed electrical cables and water pipes when installing; also check your legal requirements relating to earth bonding of extraneous metal parts.

Inspect the product at regular intervals for wear and damage.

CAUTION: Never drill through pre-stressed concrete.

CAUTION: Use appropriate sized rawl plugs if this product is being fitted onto a concrete floor.

3. UNPACKING

Remove the packaging and check all parts carefully. Contact your supplier immediately if parts are missing or damaged and do not try and assemble.

4. ASSEMBLY/INSTALLATION

Note: All pictures are for illustration purposes only. Actual product may vary by product range.

Only install the product in an area where the mounting surface and substrate are structurally sound - Strengthening modifications to the fixing surface may be required.

Also check the type of substrate you intend to fix it to e.g. brick/block, timber or concrete. Always check that the type of fixing you are going to use is compatible with the substrate.

Note: As the substrate can vary considerably, we cannot recommend any particular fixings; if in any doubt; consult a reputable fixings supplier for advice.

Maximum User Weight



4.1 Remove the Toilet Frame Leg Extensions

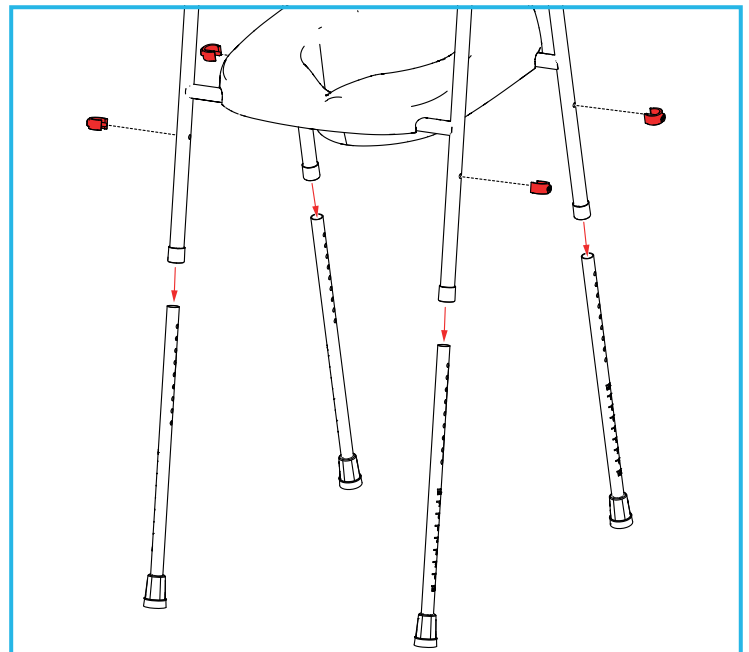

1. Remove the 4 x E-clips, then remove the toilet frame leg extensions.

4.2 Fit the Floor Fixing Leg Extensions

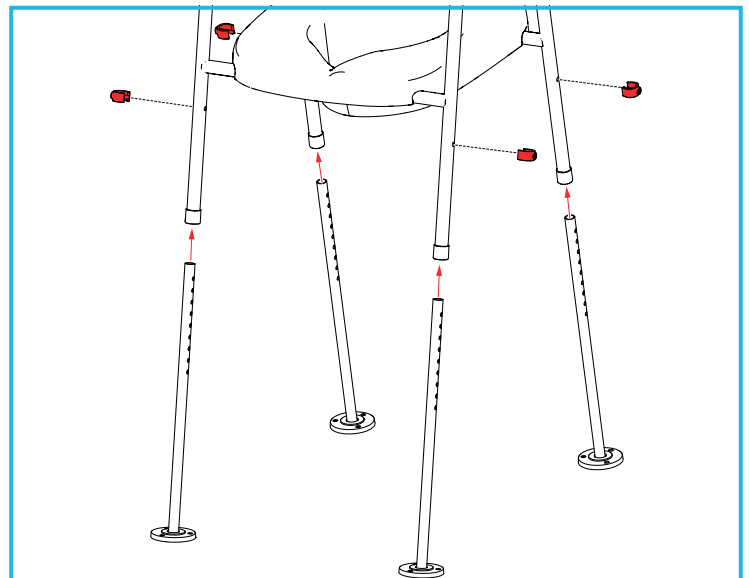

1. Insert the floor fixing kit legs into the toilet frame.

Note: Make sure that legs markings face the outside of the toilet frame

2. Slide the legs so the frame is at the required height for the toilet and the user.
3. Align the holes and replace the E-clips.

Note: Make sure that all legs have been adjusted to the same height. Height adjustment is not possible once the legs are secured to the floor.

4.3 Secure the Feet to the Floor

4.3.1 Mark the Hole Positions

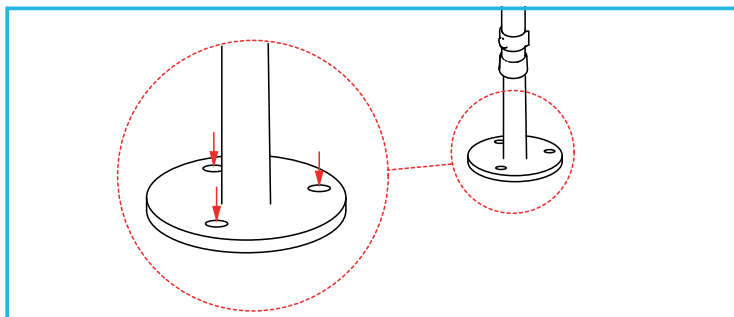

1. Place the toilet frame in the required location and mark the hole positions to be drilled.

4.3.2 Drill the Fixing Holes

1. Remove the toilet frame from the required location, then drill the holes in the positions marked, as appropriate for the chosen fixings.
2. If you are using rawl plugs for the installation, insert the rawl plugs into the fixing holes.

4.3.3 Fix the Feet to the Floor

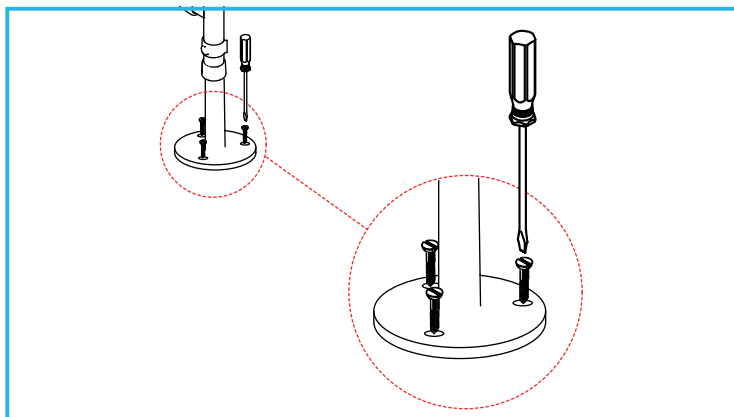

1. Using an appropriate tool for the chosen fixings, secure the floor fixing kit feet to the floor.

Note: Check that all fixings are fully secure before use.

5. MAINTENANCE

Regularly check that the screws securing the feet to the floor remain fully tight.

6. CLEANING INSTRUCTIONS

Clean regularly using a general purpose, neutral detergent and warm water.

Please check the suitability of the cleaning products before use.

Do not use abrasive cleaners or cloths as these could permanently damage the surface and invalidate any warranty.

To disinfect, wipe with a dilute bleach solution, and rinse thoroughly with fresh water.

Allow product to fully dry prior to use/storage.

7. PRODUCT DISPOSAL

This product must be thoroughly cleaned/sterilised prior to disposal.

This product is manufactured from metal and can be disposed of through Local Authority Household Waste and Recycling Centres or through Local Trade Waste Collectors.

8. PRODUCT GUARANTEE

NRS Healthcare guarantee this product for a period of 12 months, from the date of purchase, against faulty materials and workmanship.

This guarantee does not cover; fair wear & tear, abuse, misuse, interference or tampering with any part of the product.

Any guarantee issued by NRS Healthcare does not affect your statutory rights.

If you have any problems with our products, please contact us at the address below.

NRS HEALTHCARE Sherwood House, Cartwright Way, Forest Business Park
Bardon Hill, Coalville, Leicestershire, LE67 1UB, UK.

Tel: Customer Services: 0345 121 8111

Email: customerservice@nrshealthcare.co.uk

NRS Healthcare is a leading supplier of community equipment and daily living aids.
Please visit one of our websites to view our full range of products:
www.healthcarepro.co.uk or www.completecareshop.co.uk