

N72838

NRS Aluminium Swivel Bath Seat

⚠ General Safety Warning ⚠

Please make sure that you read and follow these instructions carefully. Keep these instructions in a safe place for future reference.

Maximum User Weight



1. INTENDED USE

This Swivel Bath Seat is designed to enable a user of limited mobility to rotate, whilst seated, into the bath to allow seated washing. It is suitable for most standard baths but is not suitable for corner baths, baths which have uneven / profiled top edges or some baths with deeply moulded side panels. The frame can be adjusted to fit most common bath sizes.

2. SPECIFICATION

Support Frame Width 660-760mm

Seat Width: 460mm

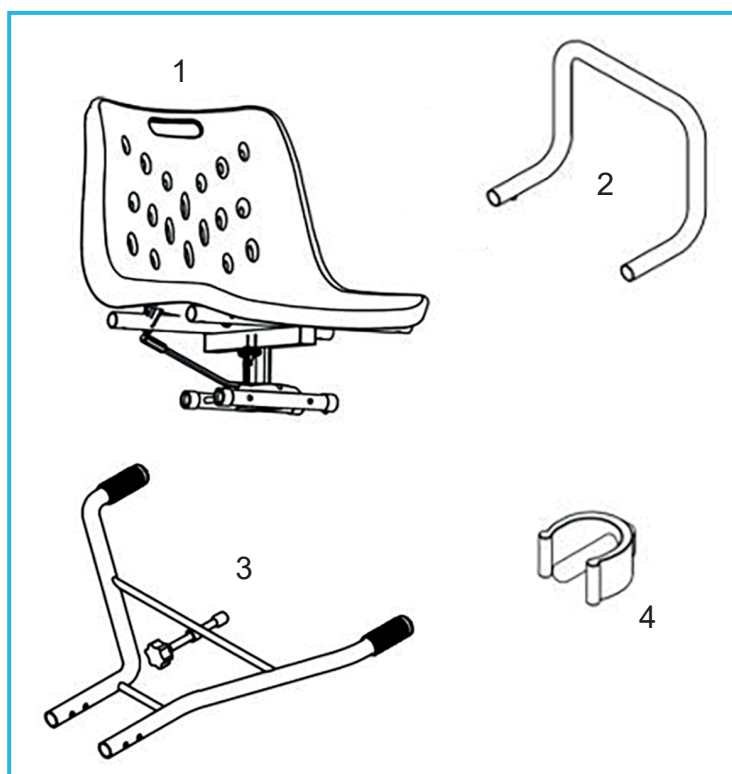

3. SAFETY

WARNING: The maximum user weight must not be more than 160Kg (25st).

CHECK all fixings are installed correctly.

MAKE SURE when placing on the bath ensure all four feet of the bath seat mounting frame are resting on the edge of the bath by at least 50mm (2").

CHECK the Handwheel screws are contacting either side of the bath wall. Do not over tighten the handwheels as this could damage the bath.

DO NOT exceed the maximum user weight limit.

ALWAYS sit in the centre of the seat.

DO NOT lean on the edges of the seat.

DO NOT stand on the seat or any other part of the product.

INSPECT at regular intervals, see care and maintenance section.

4. UNPACKING

Remove the packaging and check all parts carefully. Contact your supplier immediately if parts are missing or damaged and do not try and assemble.

4.1 Contents:

1. Seat Assembly x 1
2. Armrest x 2
3. Mounting Frame x 2
4. Fixing e-clips x 4
5. User Instruction x 1

5. ASSEMBLY/INSTALLATION

Slide each armrest (A) into the locating tubes on the seat assembly until the spring button clips "snap" into position, see diagram 2

Slide the mounting frame (B) into the locating tubes on the seat assembly, note the frame is width adjustable,

choose the correct width to suit your bath. Please refer to the instruction for correct fitting

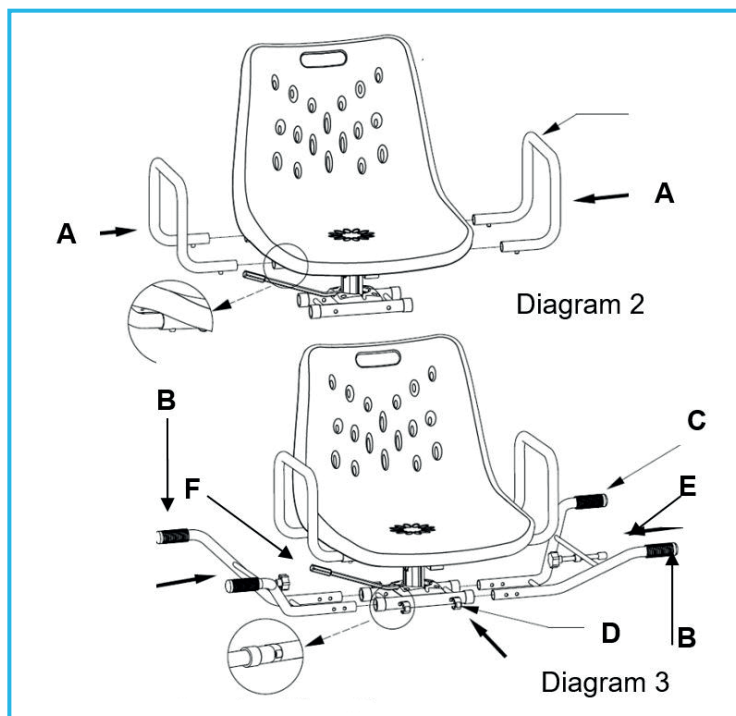

5.1 Assembling to a bath

Place the seat onto flat bath ledges.

IMPORTANT: At least 50mm (2") of ALL the mounting frame feet (C) must rest on the flat sides of the bath

If necessary extend the mounting frame by removing the fixing e-clips (D), adjusting the width of the frame so that it is closest to the external width of the bath and replacing the clips, check they are all replaced and secured correctly.

Secure the mounting frame using the clamps (E) under the seat by turning the hand wheels until secure against the walls of the bath on both sides. Check the frame is secure, but do not over tighten as this could damage the bath. The bath seat is now ready for use

Safety Note: If the Seat is removed and replaced over the bath, it is important the fixing clamps are re-adjusted and tightened as detailed above

6. IN USE

Raise the locking handle (F) and rotate until the seat is facing the user, lower the handle and lock into position.

Transfer user into seat. Raise locking handle and rotate slowly into bath, taking care when raising legs over the side of the bath.

Ensure seat is locked into position and no longer rotates freely before commencing washing

7. MAINTENANCE

It is recommended the product is wiped down after use, or at regular intervals to maintain the quality finish – see cleaning instructions

Inspect the product at regular intervals, pay particular attention to the swivel and lock movement.

Check all fixings, ensure they are secure.

Check all parts for signs of wear or damage.

If the product is not moving freely or you suspect a fault do not use – contact your dealer immediately

8. CLEANING INSTRUCTIONS.

The swivel Bath seat has a powder coated aluminium frame with a moulded polypropylene seat. Clean all parts regularly, wiping down with a mild detergent /disinfectant solution. Avoid the use of abrasive cloths and cleaners, as they can damage plastic parts.

Inspect the product regularly for signs of wear or damage

9. PRODUCT DISPOSAL

This product must be thoroughly cleaned/sterilised prior to disposal.

This product is manufactured from metal & plastic and can be disposed of through Local Authority Household Waste and Recycling Centres or through Local Trade Waste Collectors.

10. PRODUCT GUARANTEE

NRS Healthcare guarantee this product for a period of 12 months, from the date of purchase, against faulty materials and workmanship.

This guarantee does not cover; fair wear & tear, abuse, misuse, interference or tampering with any part of the product.

Any guarantee issued by NRS Healthcare does not affect your statutory rights.

If you have any problems with our products, please contact us at the address below.

If you have experienced an injury, contact us but feel free to contact the Medical and Healthcare products Regulatory Agency at:

devices.regulatory@mhra.gov.uk

UK CA NRS HEALTHCARE Sherwood House,
Cartwright Way, Forest Business Park, Bardon
Hill, Coalville, Leicestershire, LE67 1UB, UK.

CE NRS HEALTHCARE 4C Altona Road, Blaris
Industrial Estate, Lisburn, Co Antrim,
Northern Ireland BT27 5QB

Tel: Customer Services: 0345 121 8111

Email: customerservice@nrshealthcare.co.uk

NRS Healthcare is a leading supplier of community equipment and daily living aids.

Please visit one of our websites to view our full range of products:

www.healthcarepro.co.uk or www.completecareshop.co.uk