

Shower Trolley

User Guide



TRT1 Hydraulic model (standard)
TRT2 Static model
TRT3 Hydraulic model (short)
TRT4 Electric model

Chiltern
Invadex (UK) Ltd

CE
93/42/EEC

Shower Trolleys

Contents

Safety Considerations.....	1
Trolley Operation.....	2
Latch Operation & Adjustment.....	3
Charging (TRT4 only).....	4
Cleaning and Maintenance.....	4
Trouble Shooting.....	5
Spare Parts.....	6
Warranty.....	7

The Chiltern Invadex range of shower trolleys has been designed to the highest standards with safety, strength and quality in mind.

Follow the recommendations in this guide to ensure maximum benefit from your Chiltern Invadex shower trolley.

To obtain a copy of this guide in large print,
please contact customer services on

01869 365500 opt 1

or



email: sales@chilterninvadex.co.uk



Safety Considerations

- Ensure that all users read this guide before operating the shower trolley.
- Maximum user weight of 190kg (30 stone) must not be exceeded.
- Prior to each use, inspect the shower trolley sides and brackets for signs of distortion or damage. The trolley must not be used if any damage is observed.
- Under no circumstances should a client be left alone in the shower trolley.
- Although fitted with castors, these are to enable ease of movement of the trolley the device is not intended to be used for patient transportation.
- The trolley is a showering aid and is not intended for use as a bath, the shower trolley must not be filled with water.
- Where the trolley is to be used by multiple bathers, cleaning with a medical disinfectant to prevent cross contamination is strongly recommended. (follow the maintenance schedule on page 4).
- The lift/transfer of the client should be assessed and planned by a trained person.
- Any damage to the TRT4 electric actuator or charger should be reported immediately and the trolley removed from use until repaired.
- The TRT4 should be subjected to a PAT test at least annually.
- It is recommended that shower trolleys are serviced by a qualified engineer at least annually, six monthly in areas of high use (eg nursing homes).

Shower Trolley Operation

- 1 Position the shower trolley near to the showering facility and locate the outlet pipe into a suitable waste.
- 2 Prior to use, inspect the shower trolley for signs of distortion on the cot sides or latches. If the item is damaged it should be considered unsafe and replaced. The shower trolley itself must not be used if there is any sign of damage.
- 3 The trolley is designed to be angled to allow water run off through the outlet pipe. To ensure that water does not congregate around the users head, ensure that the liner is inserted correctly. (ie that the outlet pipe is located at the lower end of the trolley when the trolley is raised.)
- 4 Ensure that the brakes are in the ON position prior to attempting any transfer and remain ON whilst the trolley is occupied.
- 5 Position the trolley bed to its lowest position by depressing the down foot pedal or the down button on the hand control for the electric (TRT4) model.
- 6 Pull the latch lever down to release the cot side.
 **Note:** cot sides lower on both sides of the trolley, where one side of the trolley is unattended the latch must be checked prior to use to ensure that it is secure and will not release during use (see page 3).
- 7 Unclip the poppers on the corners of the liner and lay the liner flat.
- 8 Position the bather onto the shower liner.
 **Note:** prior to attempting any transfer the action should be planned and prepared.
- 9 Refix the shower liner corners and reposition the cot side.
 **Note:** ensure that latch locks securely into place. (see page 3)
- 10 Raise the trolley to a suitable height by depressing the up pedal or the up button on the hand control for the electric (TRT4) model.
- 11 Proceed with bathing.
- 12 When bathing is complete remove the bather by repeating operations 5-8 in reverse
- 13 Where the shower trolley is to be used by multiple bathers it is strongly recommended that the trolley is cleaned after each use using a medical disinfectant (see page 4)
- 14 The TRT4 electric actuator should be charged in accordance with the instructions on page 4.

Never leave a user unattended in the shower trolley

Latch Operation and Adjustment

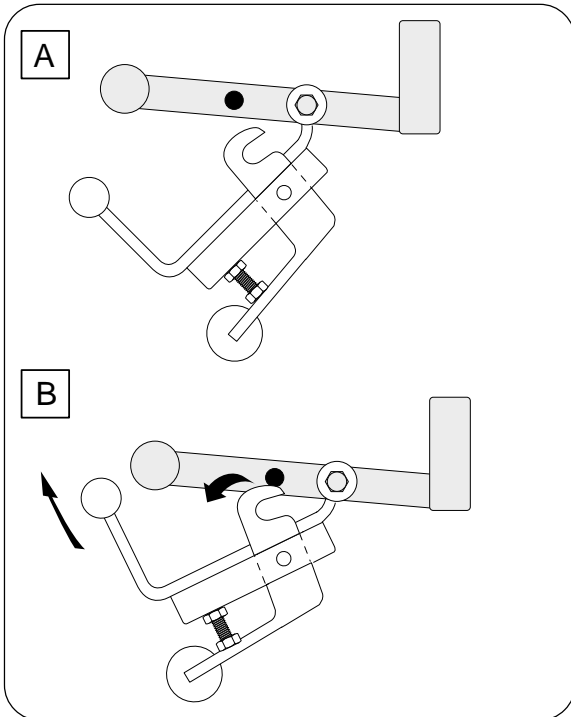

1.

As the side rail of the trolley is lifted, the latch makes contact with the locating pin. As you continue to lift the latch opens and finally clicks over the pin. As shown in A & B.

There should be no reason to open the latch manually to achieve closure.

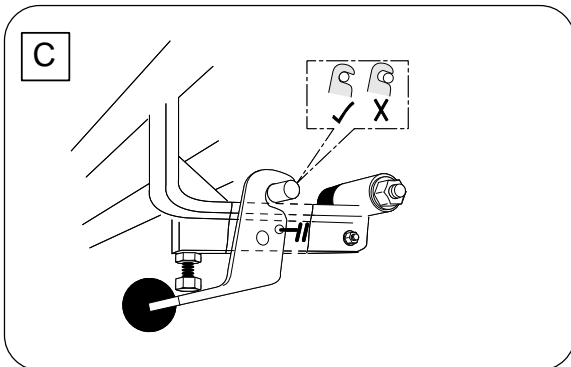

2.

When the side rail is vertical, the latch should be fully engaged as shown in C.

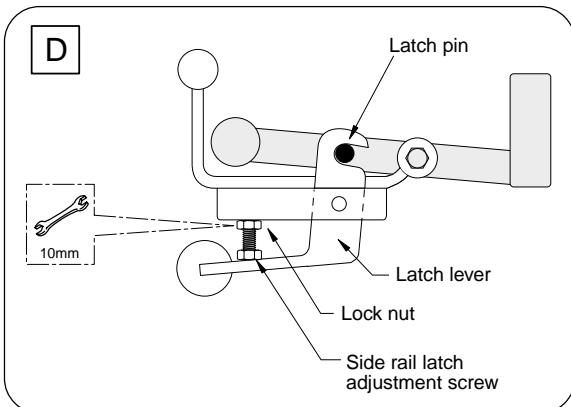

3.

If the latch is only partially engaged, the adjusting screw is too far out.

If the latch does not open automatically the screw needs adjusting outwards. A small amount of silicone grease on the top of the latch will assist with the automatic action. When any adjustment is made the lock nut must be fully tightened. See figure D.

Cleaning and Maintenance

Prior to Use

Check cot sides and latches are secure and undamaged.

After Use

Rinse the unit, particularly the bathing area with warm clean water. Use a non abrasive cleaner if soiled. For institutional use where the device is to be used by multiple bathers it is strongly recommended that a medical disinfectant is used. Contact your infection control officer for details of disinfectants approved for this use by your institution.

Weekly

Thoroughly clean the unit, particularly the bathing area with warm clean water and a non abrasive cleaner. For institutional use where the device is to be used by multiple bathers it is strongly recommended that a medical disinfectant is used. Contact your infection control officer for details of disinfectants approved for this use by your institution.

Monthly

Flush the waste pipe with a disinfectant to help avoid cross contamination.

Yearly

It is recommended that the device is serviced at least annually by a qualified engineer.

The TRT4 electric trolley should be PAT tested on an annual basis.

Re-issue

Where a trolley is owned by a loan store or other authority where it is likely to be re-issued. It is recommended that the item is fully disinfected (or a new liner obtained) and subjected to a full service prior to issue.

For details of qualified service engineers please contact Chiltern Invadex.

Charging the TRT4 Electric Trolley

It is recommended that the battery pack is fully charged prior to first use. Charging time from flat to full is approx 4 hrs.

The batteries are charged through the handset by connecting the power lead to the handset as shown.

Whilst charging the LED on the charger will flash orange and will change to green once fully charged.

It is recommended that the battery pack is charged at least weekly in domestic use, or daily in institutional use.



When the battery is running low an audible bleep will sound as a warning that the trolley should be recharged.



The handset is IP51 rated, however to prevent damage it should be protected from water ingress and should not be submerged in water.

The trolley should not be charged whilst in the bathroom or any other wet environment.

Troubleshooting

Symptom	Suggested cause	Solution
Hydraulic Lifting		
Shower trolley will not raise	Hydraulic unit fault	Requires service call
Shower trolley will not lower	Obstruction or hydraulic unit fault	Clear obstruction Requires service call
Shower trolley will not stay at desired height	Hydraulic unit fault or pedal sticking	Clean pedal and check for free movement Requires service call
Electric Lifting		
Shower trolley will not raise or lower	Battery power is low	Charge batteries see page 4
Shower trolley will not raise	Handset or actuator failure	Handset or actuator failure
Shower trolley will not lower	Obstruction, actuator or handset fault	Clear obstruction Requires service call
Shower trolley will not stay at desired height	Actuator fault	Requires service call
All trolleys		
Cot sides will not move	Weight against cot side of hinges jammed	Push cot side inwards before trying to release catch, lubricate hinges
Cot sides will not lock into position	Latch screw requires adjustment or cot sides are damaged	Refer to page 3 Requires service call
Water leaks	Liner or waste hose are damaged	Check for damage and replace faulty components

For further advice and guidance please contact Chiltern Invadex on 01869 365500 or at technical@chilterninvadex.co.uk.

To arrange a service call out please contact our service department on 01869 365500 Opt 3 or at servicedept@chilterninvadex.co.uk.



If there is any doubt about the condition of the trolley it must be discontinued from use until a service call has been completed.

Spare Parts

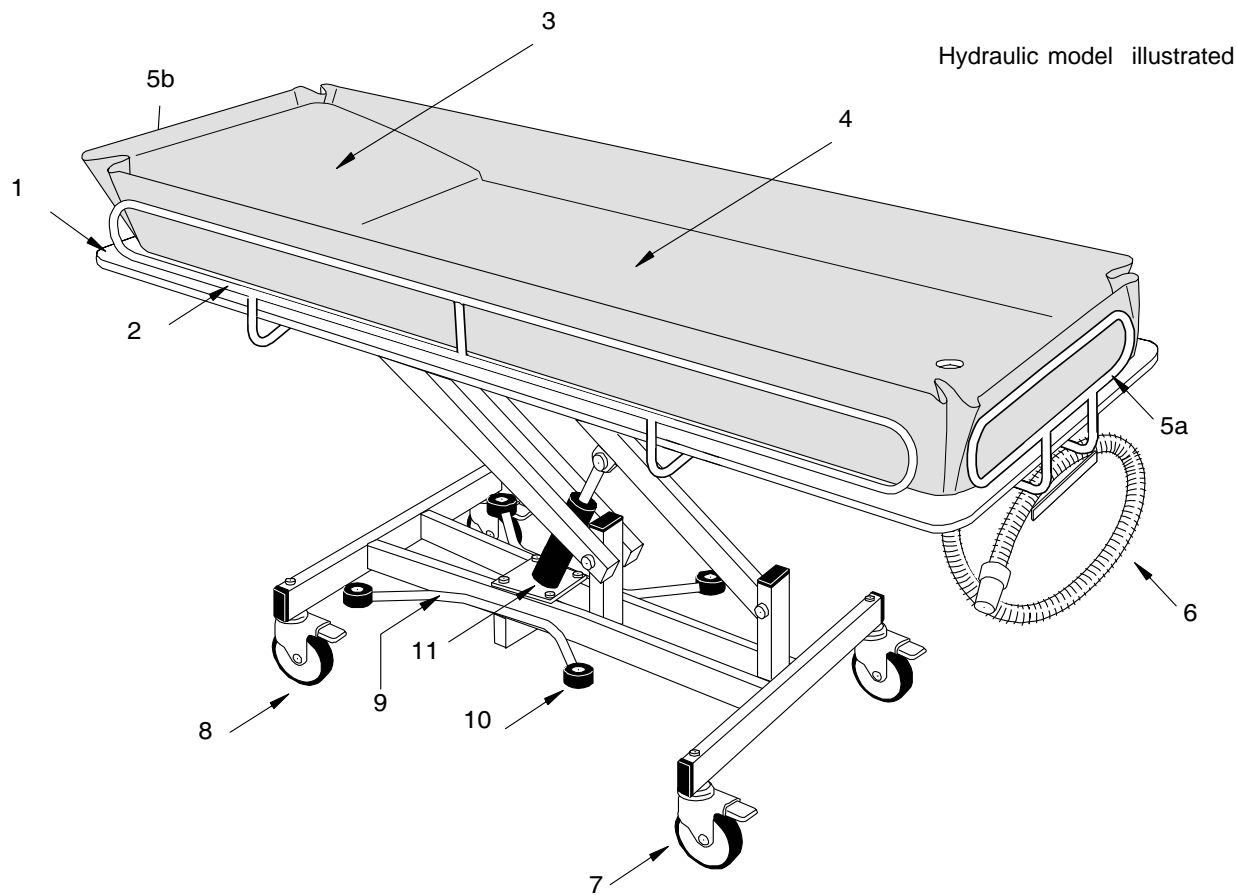

Item Nr	Description	Part number	Model Ref
1a	*Plastic top - standard length (1930mm)	TRTS012	TRT1, TRT2, TRT4
1b	*Plastic top - short length (1600mm)	TRTS015	TRT3
1c	*Plastic top - special dimensions	TRTS013	TRT#SPEC
2a	*Cot side - standard length	TRTS032	TRT1, TRT2, TRT4
2b	*Cot side - short length	TRTS038	TRT3
3	Wedge cushion	TRTS003	All models
4a	Trolley liner - standard length	TRTS001V	TRT1, TRT2, TRT4
4b	Trolley liner - short length	TRTS009V	TRT3
4c	Trolley liner - special dimensions	TRTS002V	TRT#SPEC
5a	*Cot end (head end)	TRTS033	All standard models
5b	*Cot end (waste pipe end)	TRTS036	All standard models
6a	Waste outlet pipe - standard length (1m)	TRTS010	All models
6b	Waste outlet pipe - special length	TRTS014	Optional extra
7	*5" braked castor	202-00031	All models
8	*5" straight steering castor	202-00030	All models
9	*Foot pedal assembly	TRTS004	TRT1, TRT3
10	Foot pedal rubber	CH0181	TRT1, TRT3
11	*Hydraulic ram	TRTS006	TRT1, TRT3
	*Cot side latch assembly (not shown)	TRA117	All models
Electric parts TRT4 only (not shown)			
	*Electric actuator	TRTS026	TRT4
	Control/battery box assembly	TRTS027	TRT4
	Charger	TRTS029	TRT4
	Handcontrol	CH0653	TRT4

In the interests of user safety it is recommended that parts indicated * should be installed by a qualified engineer

Warranty

Your Chiltern Invadex Shower Trolley carries a 12 month warranty from the date of purchase, subject to the following conditions.

- 1 Should you experience any problems with our workmanship or materials within the first 12 months period please contact your point of purchase.
- 2 Repairs made during the warranty period will be carried out free of charge, provided the product has been used strictly in accordance with the guidelines set out in this user guide.
- 3 Our warranty does not cover replacements, adjustments or repairs which may be required as result of normal wear and tear, wilful or accidental damage, misuse, neglect or any other cause which is beyond the control Chiltern Invadex.
- 4 Modifications and repairs made to this product by unauthorised persons will render the warranty void.
- 5 Only parts manufactured or approved by Chiltern Invadex shall be used to repair this product. Use of unauthorised parts will invalidate all warranties and remove all liability from Chiltern Invadex for the safety of this product.
- 6 Chiltern Invadex shall in no event be liable for any damages, costs or expenses arising from any claim made under this warranty (save for any legal liability of Chiltern Invadex for death or personal injury resulting from the companys negligence in respect of its products.)
- 7 This warranty does not affect your statutory rights.

Please fill in the information below for future reference

Dealers Name _____

Address _____

Post Code _____

Telephone _____

Model Number _____

Serial Number _____

Date of purchase _____

Showering and Bathing Shower Trolley Range



Chiltern Invadex (UK) Limited
126 Churchill Road
Bicester
Oxfordshire
OX26 4XD

Tel: 01869 365500
Fax: 01869 365588
Email: sales@chilterninvadex.co.uk

TRT4 only



WEEE producer number
WEE/JD1274RU

The crossed wheelie bin symbol shown on this product indicates that the item must not be disposed of with general household waste. Proper recovery of your waste electronic and electrical equipment will ensure safety of human health and the environment.

For more information where the product can be safely disposed of please contact your Local Authority, the dealer from where the product was purchased or Chiltern Invadex (UK) Limited.



FM553189
BS EN ISO 9001:2008

