

P64491

NUVO Mobile Shower Chair

⚠ General Safety Warning ⚠

Please make sure that you read and follow these instructions carefully. Keep these instructions in a safe place for future reference.

Maximum User Weight



1. INTENDED USE

The NUVO Mobile Shower Chair has been designed to be used in a bathroom or shower, to provide stable seating for users with reduced mobility who are unable to stand during showering. This product is supplied in parts, some basic assembly is required. The Chair frame has been made from high quality stainless steel offering superior corrosion resistance.



2. SAFETY

Warning: The maximum user weight must not be more than 166Kg (26st).

Make sure the seat is securely fitted to the frame.

Do not stand on the chair under any circumstances, failure to comply can result in serious injury.

Do not sit or rest on the arm rests under any circumstances, failure to comply can result in serious injury.

Make sure that all castors are LOCKED before getting in and out of the shower chair, whilst showering or if leaving the user for any period of time.

Inspect the product regularly to make sure it is not damaged.

Do not use if the castors are damaged.

Plan route before moving to avoid obstacles.

Wipe dry after each use.

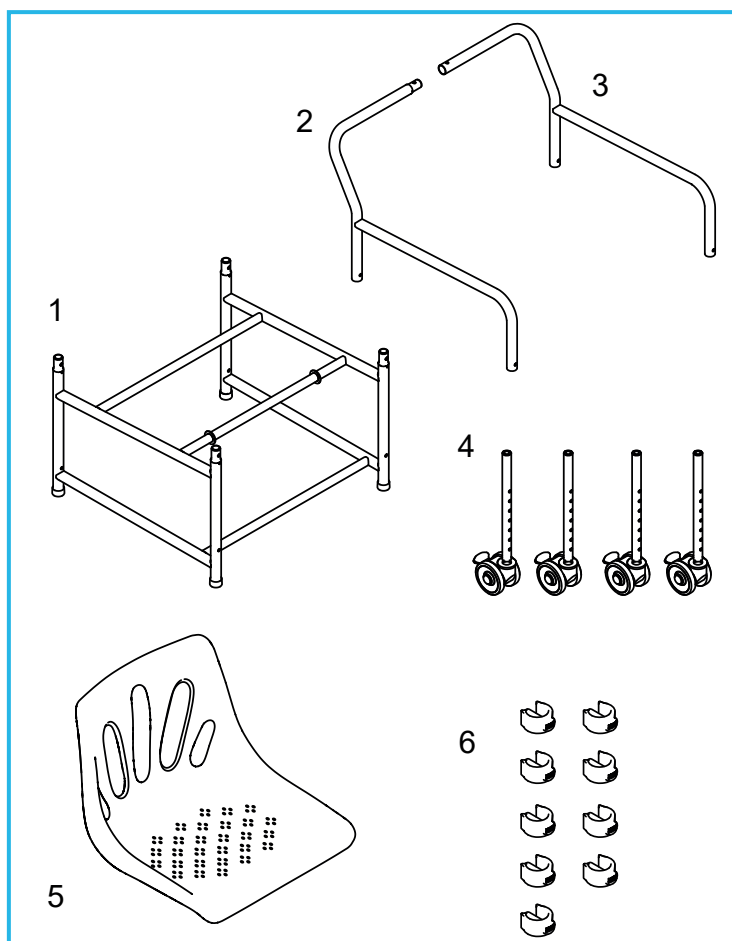

3. UNPACKING

Remove the packaging and check all parts carefully. Contact your supplier immediately if parts are missing or damaged and do not try and assemble.

3.1 Contents:

1. Base Frame Assembly x 1
2. RH Arm Rest Assembly x 1
3. LH Arm Rest Assembly x 1
4. Castor Leg Assembly x 4
5. Plastic Moulded Seat x 1
6. E-Clips x 9

4. ASSEMBLY/INSTALLATION

4.1 Attach the Seat:

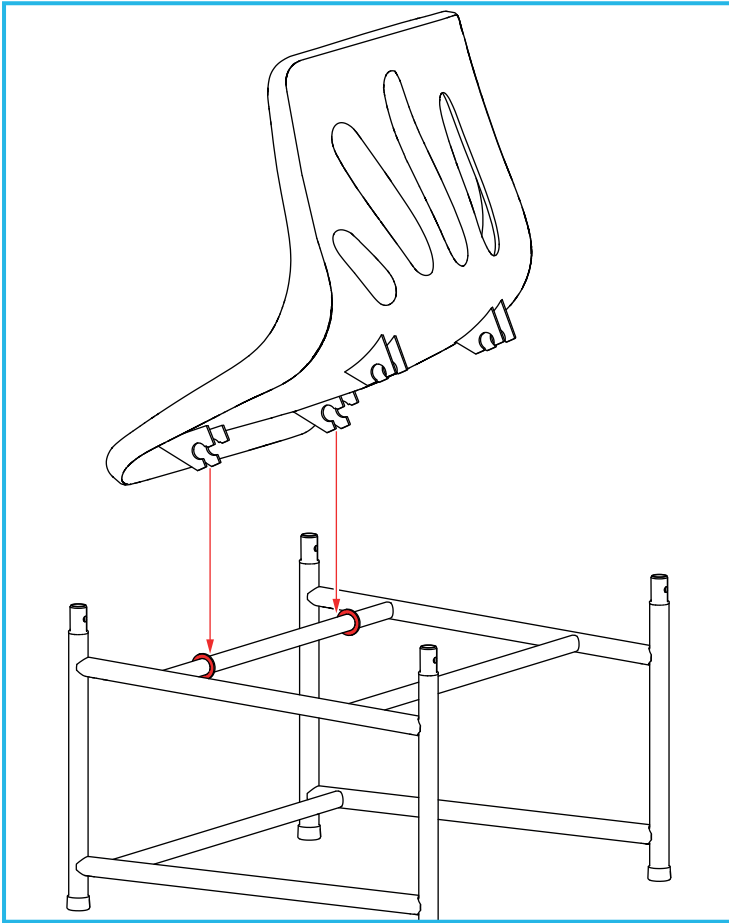

Attach the front of the seat to the seat frame assembly using the front clips first.

Note: Make sure the front seat clips fit inside the metal spacers on the front crossbar.

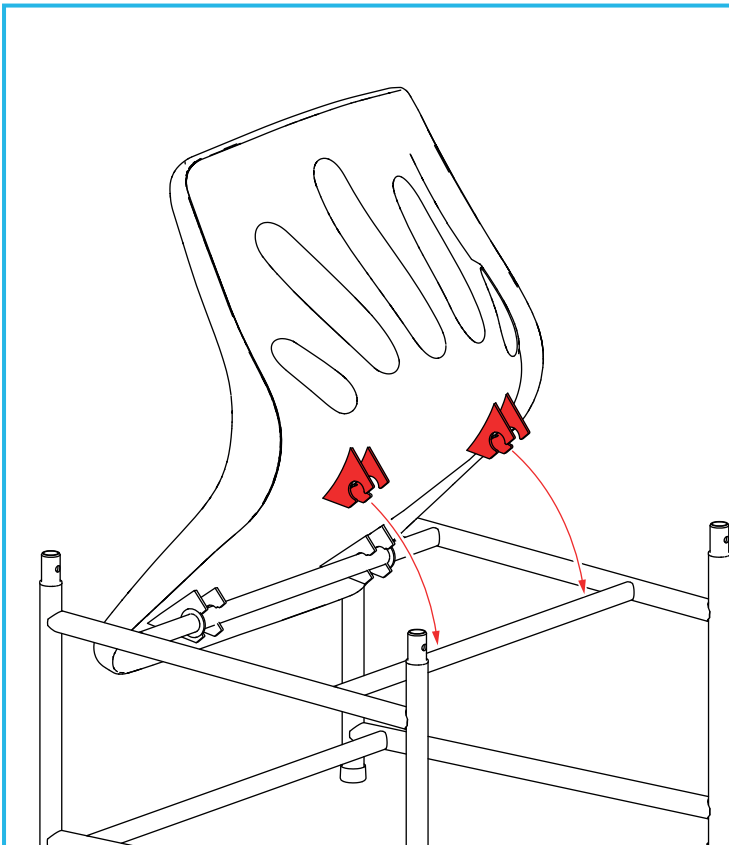

Rotate the seat until the rear clips click into place.

4.2 Assemble the LH/RH Arm Rests

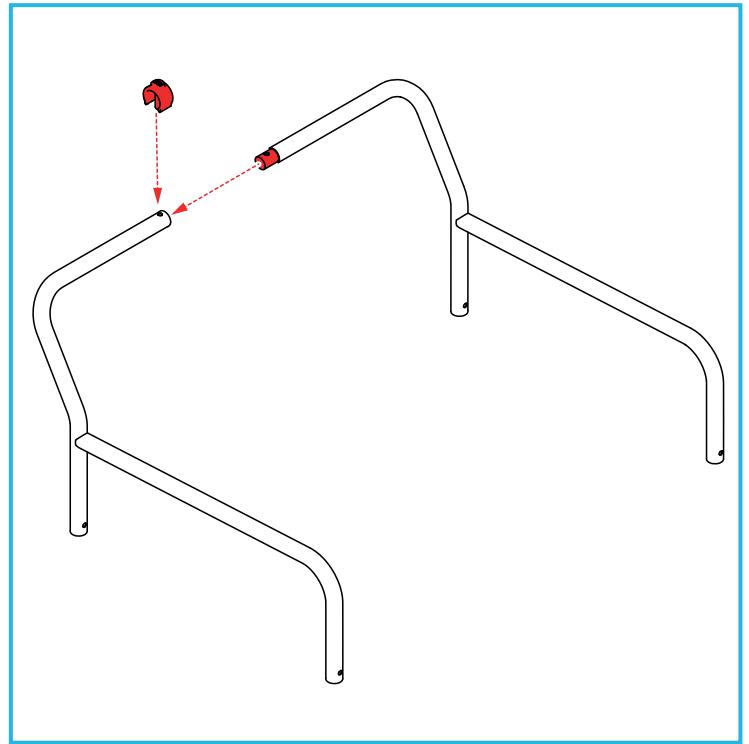

Slot the arm rests together as shown. Secure the arm rests using 1 x E-clip.

4.3 Attach the Arm Rest Assembly to the Seat Frame

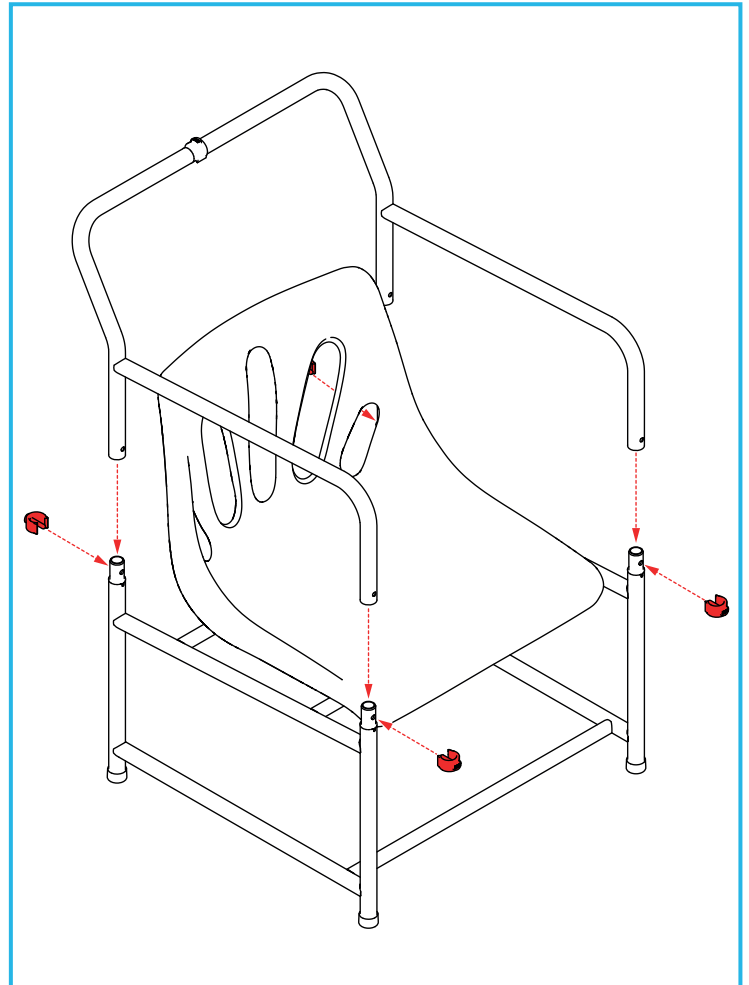

Slot the arm rest assembly onto the seat frame assembly.

Secure the arm rest assembly using 4 x E-clips.

4.4 Attach the Leg/Castor Assemblies

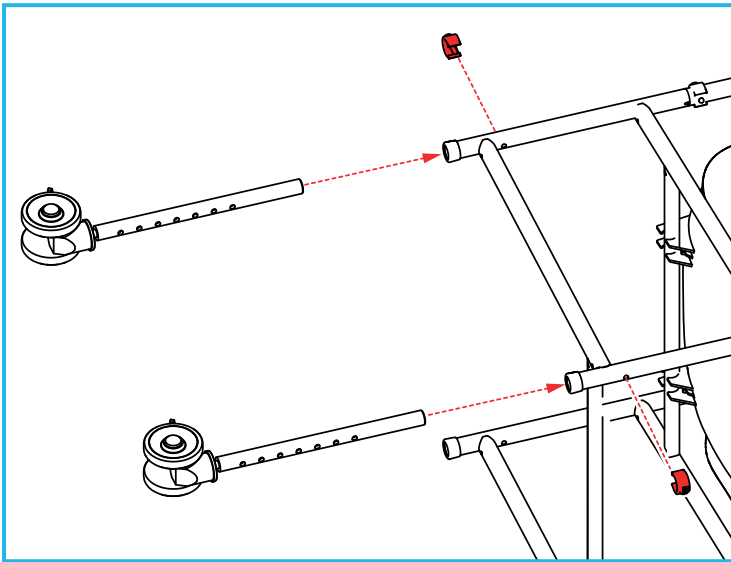

Place the seat frame assembly on its side and attach the leg/castor assemblies using 2 x E-clips.

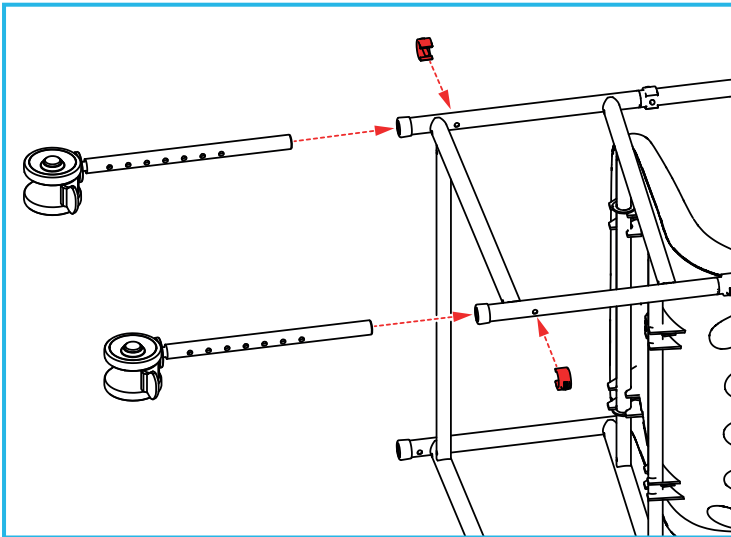

Repeat the step for the opposite side.

Note: Make sure that all legs have been adjusted to the same height.

4.5 Adjusting the seat height

Note: The seat height has an adjustment range from 400mm to 550mm in 25mm increments.

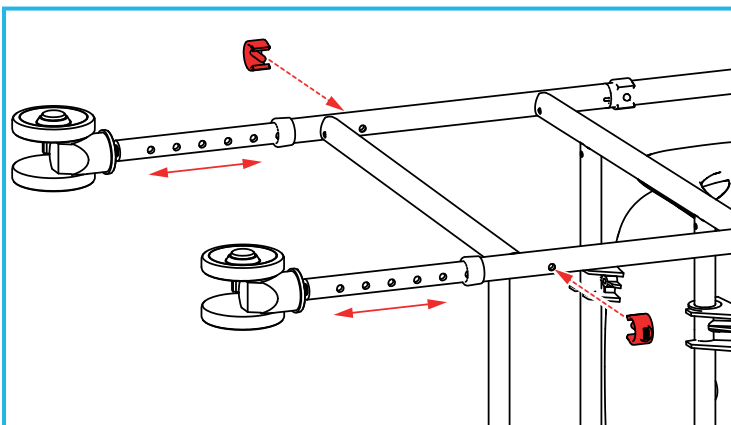

Place the seat frame assembly on its side, remove the 2 x E-clips and adjust the legs to the required height.

Secure the legs with the 2 x E-clips.

Repeat for the opposite side.

Note: Make sure that all legs have been adjusted to the same height.

5. IN USE

Warning: Make sure the castors are locked before the user lowers or raises from the chair.

5.1 Locking/Unlocking the Castors:

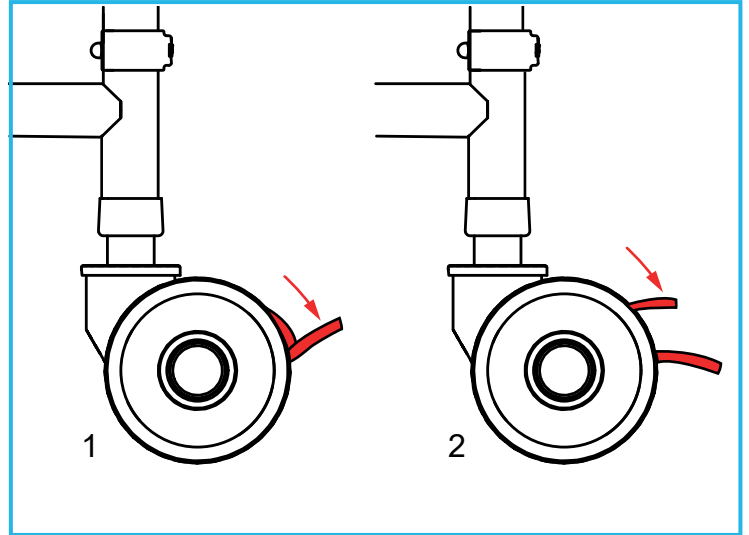

1. Push the locking tabs down to lock the castors.
2. Push the release tabs down to unlock the castors.

6. MAINTENANCE

Inspect the product regularly for signs of wear or damage, pay particular attention to the condition of the castors and plastic joint spacers.

Any suspected faults or damage must be reported to the supplier and the product taken out of use immediately.

Check that all fixing clips and plastic joint spacers are fitted correctly with no excessive movement.

7. CLEANING INSTRUCTIONS.

Please check the suitability of the cleaning products before use.

Do not use abrasive cleaners or cloths as these could permanently damage the surface and invalidate any warranty.

Clean regularly using a general purpose, neutral detergent and warm water.

DO NOT use solvents to clean the product.

To disinfect, wipe with a dilute bleach solution, and rinse thoroughly with fresh water.

Make sure that all dirt and debris is removed from around the castors.

This product is suitable for thermal decontamination and can be steam cleaned or autoclaved on cleaning cycles up to 80°C.

8. PRODUCT DISPOSAL

This product must be thoroughly cleaned/sterilised prior to disposal.

This product is manufactured from metal and plastic and can be disposed of through Local Authority Household Waste and Recycling Centres or through Local Trade Waste Collectors.

9. PRODUCT GUARANTEE

NRS Healthcare guarantee this product for a period of 12 months, from the date of purchase, against faulty materials and workmanship.

This guarantee does not cover; fair wear & tear, abuse, misuse, interference or tampering with any part of the product.

Any guarantee issued by NRS Healthcare does not affect your statutory rights.

NRS HEALTHCARE Sherwood House, Cartwright Way, Forest Business Park, Bardon Hill, Coalville, Leicestershire, LE67 1UB, UK.

Tel. Customer Services: 0345 121 8111

Email: customerservice@nrshealthcare.co.uk

NRS Healthcare is a leading supplier of community equipment and daily living aids, to view our full range, visit our website:

www.nrshealthcare.co.uk