

# USER INSTRUCTIONS

## SECURE FIT SLING RANGE

M29495	Small	M29501	Medium	M29513	Large
--------	-------	--------	--------	--------	-------

### General Safety Warning

Please make sure that you read and follow these instructions carefully. Keep these instructions in a safe place for future reference.



### Maximum User Weight



## 1. INTENDED USE

The Secure Fit Sling range is designed to suit a wide range of users and transfer needs. They can be used on hoists fitted with a conventional spreader bar (i.e. with hooks at either end from which looped straps may be suspended). If you are unsure about compatibility with the spreader bar contact NRS customer services, contact details overleaf.

## 2. SIZE GUIDE

Sling Size	Small	Medium	Large
Colour Code			
Sling Code	M29495	M29501	M29513
User Measurements Shoulder to Sacrum	400- 550mm 15 <sup>3</sup> / <sub>4</sub> -21 <sup>1</sup> / <sub>2</sub> "	550- 700mm 21 <sup>1</sup> / <sub>2</sub> -27 <sup>1</sup> / <sub>2</sub> "	700- 800mm 27 <sup>1</sup> / <sub>2</sub> -31 <sup>1</sup> / <sub>2</sub> "

## 3. SAFETY

**Warning:** The maximum user weight must not be more than 200Kg (31st).

Persons using this equipment should have received appropriate training or instruction.

Hoisting transfers should only be attempted following a comprehensive risk assessment and should be performed in accordance with local Moving & Handling Guidelines.

Before every lift, visually inspect the sling to ensure it is fit for purpose. Refer to the Inspection Routine section of this guide for the recommended method. If in doubt do not use the sling.

## 4. UNPACKING

Remove the packaging and check all parts carefully. Contact your supplier immediately if parts are missing or damaged and do not try and assemble.

## 5. FITTING & OPERATIONAL INSTRUCTIONS

### 5.1 Fitting from the seated position

- Place the sling behind the client with the top edge of the sling level with the base of the client's neck.
- Position the sling by pulling the bottom edge briskly from left to right and back again, the bottom edge of the sling can be positioned 25-50 mm under the client's buttocks.
- Pass the internal leg straps between the client's legs and thread the left loop through the right.
- By pulling gently upwards on the external leg straps, it should be clear that the client's legs are fully enclosed by the sling, with the straps crossed between the client's thighs. If this has not been achieved, undo the straps and go back to step 3 and repeat.

- Attach the shoulder straps to the hoist spreader bar. (The middle loop on each shoulder strap will give a reasonably upright sitting position.) A more reclined position can be achieved by using a longer loop. For a more upright posture choose a loop closer to the sling.
- Attach the leg straps to the hoist spreader bar. The middle loop on each leg strap will give a reasonably natural sitting position. The client's knees can be raised by selecting a loop closer to the sling.
- Ensure that all loops are fully attached to the spreader bar, and that the sling is well positioned and not attached in any way to the seat or other obstacle.
- Ensure client is secure and comfortable.
- Raise the hoist spreader bar to lift the client just off the surface. Check that all loops are connected and the client is secure and comfortable prior to completing the transfer.
- Do not attempt to adjust or detach any strap while the patient is being hoisted.

### 5.2 Fitting from the Lying position

Roll the client onto the sling, ensuring that the top edge of the sling is level with the base of the neck, and the bottom edge is positioned just below the coccyx. Follow the instructions from point 3 of Section 5.1.

## 6. INSPECTION INFORMATION

**The following notes are a guide to the recommended inspection procedures for slings.**

If carried out thoroughly, at regular intervals, lifting and hoisting operations can be carried out with confidence, and the risk of injury due to sling failure is significantly reduced.

Before every lift, visually inspect the slings structural integrity. Use the diagrams below as a guide. If there are any signs of damaged fabric or stitching do not use.

If you are unsure, do not use the sling, withdraw from service immediately. The product should then be either discarded, or clearly labelled: "Not for use" and assessed at the earliest opportunity by a competent individual.

## 7. SLING INSPECTION PROCEDURE

The following procedure is recommended to help ensure that lifting and hoisting operations can be carried out with confidence and the risk of accident due to sling failure is minimised.

Open the sling out fully on a flat surface.

Check all retaining straps for cuts, nicks or degradation of any kind.

Carefully check all stitching.

Check the material near to any attachment points.

Pay particular attention to the areas of high stress as shown in the diagram.

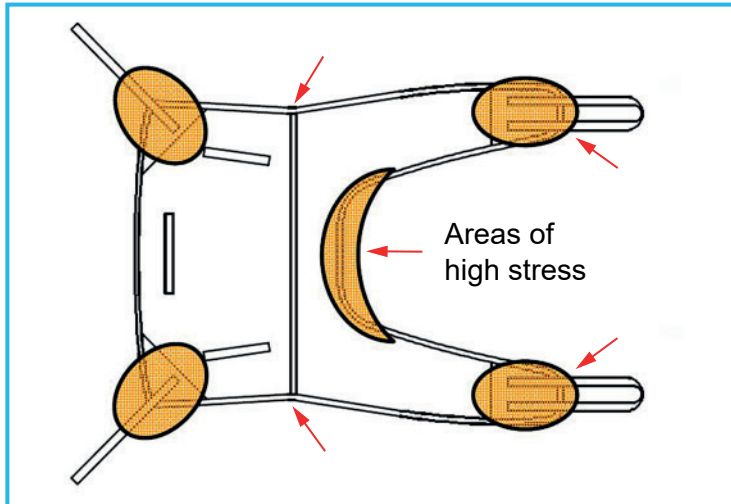

Checks should be carried out to both sides of the sling in the same manner.

Discolouration may also indicate fabric degradation.

Carefully examine all stitching.

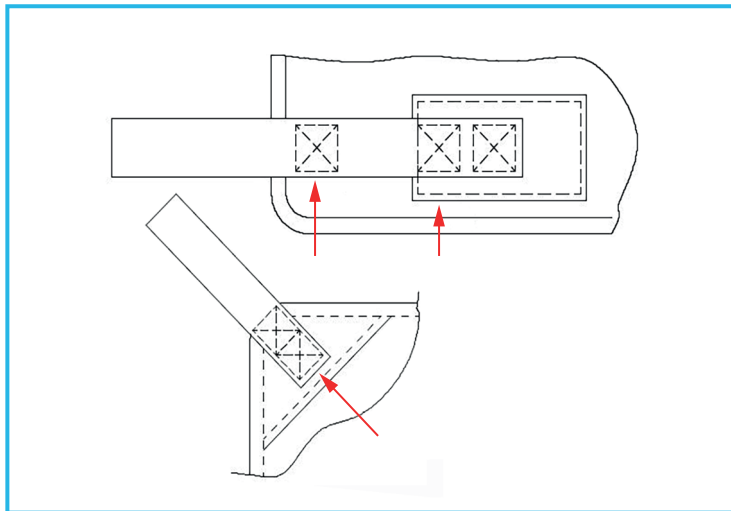

All stitching must be intact.

There should be no material degradation around any stitching.

## 7.1 Strapping Inspection

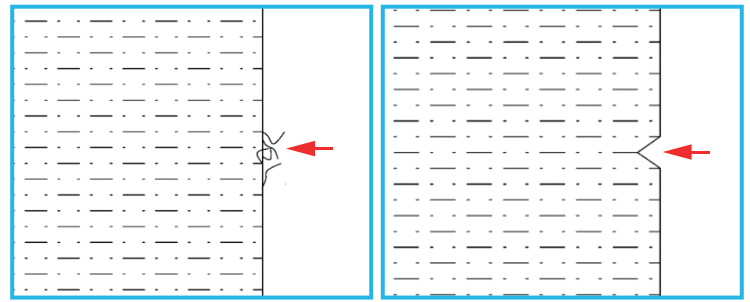

A few loose strands are acceptable.

A visible nick of even 1mm **SHOULD BE DEEMED UNSAFE.**

## 8. CLEANING INSTRUCTIONS.

- Machine wash warm at up to 70°C.
- For effective decontamination, wash at greater than 65°C for at least 10 minutes.
- Do not use bleach, biological detergents or detergents containing bleach.
- Do not spot clean with strong chemicals.
- Do not iron.
- Do not dry clean.
- Tumble dry only on 'cool' setting or air dry at very low temperatures.

## 9. PRODUCT DISPOSAL

This product must be thoroughly cleaned/sterilised prior to disposal.

This product is manufactured from fabric and can be disposed of through Local Authority Household Waste and Recycling Centres or through Local Trade Waste Collectors.

## 10. PRODUCT GUARANTEE

NRS Healthcare guarantee this product for a period of 12 months, from the date of purchase, against faulty materials and workmanship.

This guarantee does not cover; fair wear & tear, abuse, misuse, interference or tampering with any part of the product.

Any guarantee issued by NRS Healthcare does not affect your statutory rights.

If you have any problems with our products, please contact us at the address below.

If you have experienced an injury, contact us but feel free to contact the Medical and Healthcare products Regulatory Agency at:

[devices.regulatory@mhra.gov.uk](mailto:devices.regulatory@mhra.gov.uk)



**NRS HEALTHCARE** Sherwood House,  
Cartwright Way, Forest Business Park, Bardon  
Hill, Coalville, Leicestershire, LE67 1UB, UK.



**NRS HEALTHCARE** 4C Altona Road, Blaris  
Industrial Estate, Lisburn, Co Antrim,  
Northern Ireland BT27 5QB

Tel: Customer Services: 0345 121 8111

Email: [customerservice@nrshealthcare.co.uk](mailto:customerservice@nrshealthcare.co.uk)

**NRS Healthcare** is a leading supplier of community equipment and daily living aids.

Please visit one of our websites to view our full range of products:

[www.healthcarepro.co.uk](http://www.healthcarepro.co.uk) or [www.completecareshop.co.uk](http://www.completecareshop.co.uk)