

S05883

NUVO Open Back Toilet Frame

⚠ General Safety Warning ⚠

Please make sure that you read and follow these instructions carefully. Keep these instructions in a safe place for future reference.

Maximum User Weight



1. INTENDED USE

The height adjustable NUVO Open Back Toilet Frame has been designed to assist those who have difficulty in lowering onto, or rising from a standard toilet. They can also be used in conjunction with a raised toilet seat. An optional floor fixing kit is also available (P63989).

2. SAFETY

WARNING: The maximum user weight must not be more than 190Kg (30st).

MAKE SURE the floor surface is level and even to avoid rocking.

MAKE SURE all legs are set at the same height to avoid rocking.

DO NOT use if the rubber feet are damaged.

Inspect the product at regular intervals for signs of wear or damage.

3. UNPACKING

Remove the packaging and check all parts carefully. Contact your supplier immediately if parts are missing or damaged and do not try and assemble.

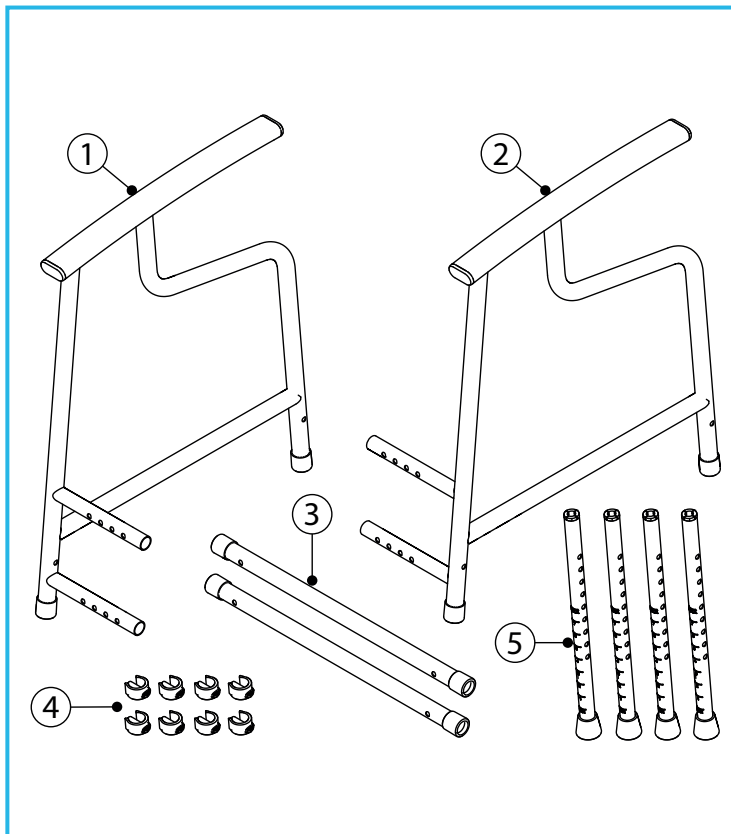

3.1 Contents:

1. RH Side Frame Assembly x 1
2. LH Side Frame Assembly x 1
3. Connecting Crossbars x 2
4. E-clips x 8
5. Legs Extensions x 4

4. ASSEMBLY

4.1 Fitting the Connecting Crossbars

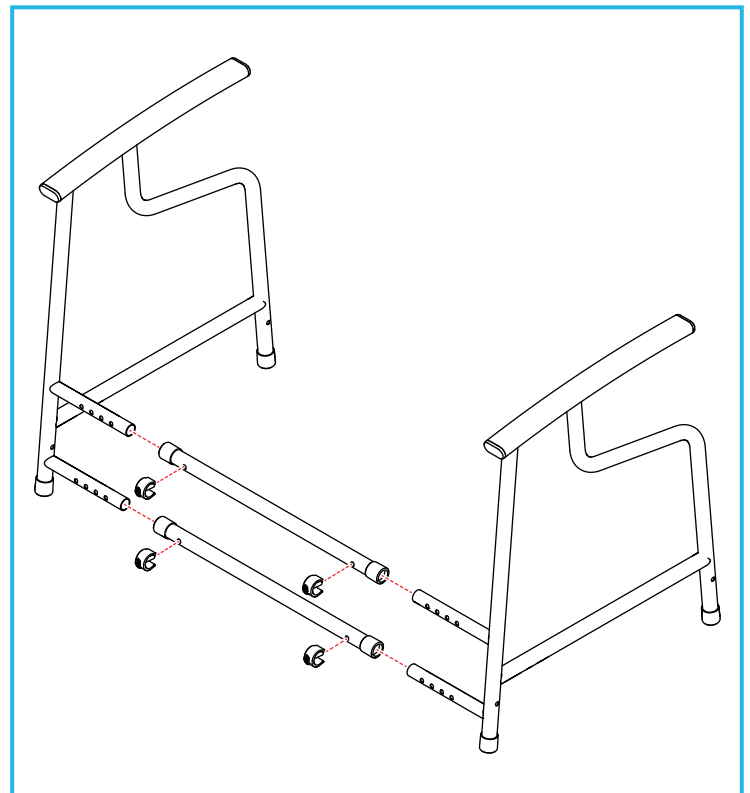

1. Connect the 2 x connecting crossbars to the side frame assemblies and set to the correct width for the toilet and user.
2. Align the holes and secure with the 4 x e-clips.

Note: Make sure that the side frames have been set to the same width and the e-clips are fully secure.

4.2 Fitting the Legs

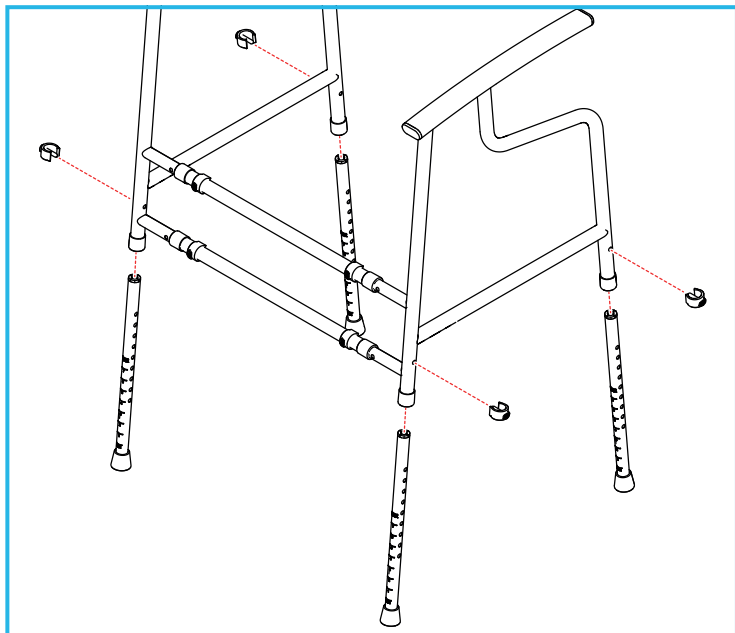

Insert the legs and set to the correct height for the toilet and user, then secure with the 4 x e-clips.

Note: Make sure that all legs have been set to the same height and the e-clips are fully secure.

4.3 Fitting the Floor Fixing Kit

Please refer to the user instructions provided with the optional floor fixing kit (P63989).

5. IN USE

5.1 Adjusting the Toilet Frame Height

1. Remove the e-clip and slide the leg extension to required height for the toilet and user.
2. Align the holes and re-insert the e-clip.
3. Repeat for all four legs ensuring they are set to equal height.
4. Check the seat is level and the product is stable before use.

Note: Make sure that all legs have been set to the same height and the e-clips are fully secure.

5.2 Adjusting the Toilet Frame Width

1. Remove the e-clips and adjust to the correct width for the toilet and user.
2. Align the holes and re-insert the e-clips.

Note: Make sure that each side has been set to the same width and the e-clips are fully secure.

6. MAINTENANCE

Inspect the product regularly for signs of wear or damage, pay particular attention to the condition of the ferrules.

Check that all fixing clips are inserted correctly and there is no excessive movement in the legs or seat.

If you see or suspect a fault do not use and contact your supplier immediately.

7. CLEANING INSTRUCTIONS.

Note: Please check the suitability of the cleaning products before use. Do not use abrasive cleaners or cloths as these could permanently damage the surface and invalidate any warranty.

Clean the frame regularly, using a general purpose, neutral detergent and warm water.

To disinfect, wipe with a dilute bleach solution, and rinse thoroughly with fresh water.

Allow product to fully dry prior to use/storage.

8. ACCESSORIES & SPARE PARTS

P63989 - NUVO Floor Fixing Kit.

P11668 - NUVO Spares Kit:

- Oval End Cap x 4
- Ferrule x 4
- E-clips x 4
- Anti-rattle collar x 4

For more details please visit our website:

www.healthcarepro.co.uk or call Customer Services.

9. PRODUCT DISPOSAL

This product must be thoroughly cleaned/sterilised prior to disposal.

This product is manufactured from metal and plastic and can be disposed of through Local Authority Household Waste and Recycling Centres or through Local Trade Waste Collectors.

10. PRODUCT GUARANTEE

NRS Healthcare guarantee this product for a period of 12 months, from the date of purchase, against faulty materials and workmanship.

This guarantee does not cover; abuse, misuse, interference or tampering with any part of the product.

Any guarantee issued by NRS Healthcare does not affect your statutory rights.

NRS HEALTHCARE Sherwood House, Cartwright Way, Forest Business Park
Bardon Hill, Coalville, Leicestershire, LE67 1UB, UK.

Tel: Customer Services: 0345 121 8111

Email: customerservice@nrshealthcare.co.uk

NRS Healthcare is a leading supplier of community equipment and daily living aids.
Please visit one of our websites to view our full range of products:
www.healthcarepro.co.uk or www.completecareshop.co.uk