



Electric Mini Exercise Bike



VP159R

Usage and Maintenance Instructions



**This Manual is part of the product and should be kept with it at all times.
If the product is passed on or sold the manual must be included.**

INTRODUCTION

Thank you for deciding to purchase the Electric Mini Exercise Bike from Aidapt. The Electric Mini Exercise Bike is manufactured from the finest materials and components available, when used correctly it is designed to give many years of reliable trouble-free service.

BEFORE USE

- Carefully remove all packaging. Avoid using any knives or other sharp instruments as this may damage the surface of the product.
- Check the product and its mains lead for any signs of damage. If you see any damage do not use and contact your supplier for support.

INTENDED USE

The mini cycle exerciser from Aidapt can help to improve circulation and muscle strength and is ideal for those keen to exercise from the comfort of their own homes. It can be used to exercise your legs seated or lying down, or on a table for arm exercises.

PRODUCT SAFETY

Carefully read through the instructions contained in this manual. It provides you with important information about safety, use and maintenance of the appliance.

1. Make sure that the mains supply Voltage is suitable for the machine before plugging it in (230 V). The holes in the wall socket must match the pin configuration for the plug on the machine. If this is not the case please contact your supplier.
2. This unit has been designed for indoor and home use only.
3. Do not leave this unit unattended when it is plugged in. Unplug it from the wall socket after each exercise session.
4. Place the appliance on a firm flat stable surface with at least 0.5 metres of free to the sides and rear of the unit before use.
5. Periodically check this product and its mains lead for any signs of damage and wear. Should you find any signs of damage stop using this product immediately and contact your supplier.
6. There are no user servicable parts in this product.
7. Do not use in bathrooms, or in wet or damp locations.
8. To unplug the machine first put the switch to the "0" position and then unplug from the wall socket.
9. Please consult a medical professional before undertaking a new form of exercise or using new exercise equipment.
10. As with all forms of exercise, do not use the machine if you feel unwell or immediately after eating.
11. Always ensure that you perform an adequate Warm Up before and Cool Down after exercising.

12. Wear suitable clothing and footwear.
13. Do not touch or insert any objects into the moving parts while the machine is in use.
14. This appliance can be used by children aged from 8 years and above and persons with reduced physical, sensory or mental capabilities or lack of experience and knowledge if they have been given supervision or instruction concerning use of the appliance in a safe way and understand the hazards involved.
15. Children shall not play with the appliance.
16. Cleaning and user maintenance shall not be made by children without supervision.
17. Do not place the mains lead beneath a carpet or rug.
18. Ensure that the cable does not come into contact with the pedals while in use.

ASSEMBLY INSTRUCTIONS

Take the unit out of the box and place it on the floor as show in Figure 1.

The assistance of a second person is advisable for the assembly work.

zMake sure that you have all of the pieces:

A	Main Body)	D	Screw x4
B	Stabiliser Bar1	E	Grower Washer x4)
B1	Rear Stabiliser Bar)	F	Hexagonal Key
C-L	Left Pedal	G	Pedals
C-R	Right Pedal)	H	Screw

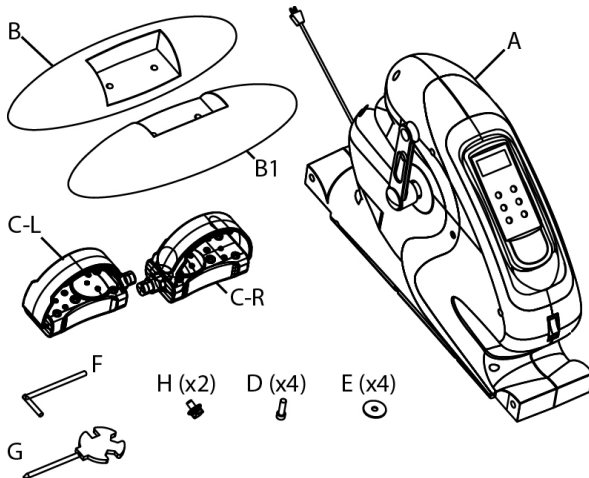

Figure 1

FITTING THE STABILISERS

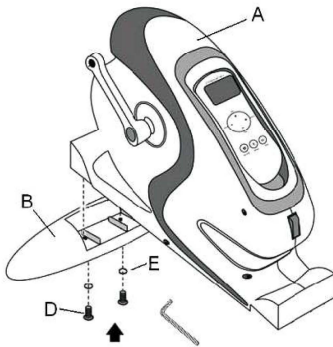

Fig. 2

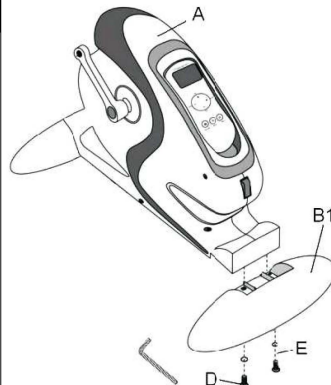

Fig. 3

1. Install the stabiliser bar (B) with the main body (A) as shown in Fig. 2.
2. Keep the screw (D) and grower washer (E) firmly and drive them slowly with the hexagonal key (F).
3. Install the rear stabiliser bar (B1) marked with the main body (A) as shown in Fig. 3.
4. Apply the same procedure as step 2 above.

ATTACHING THE PEDALS

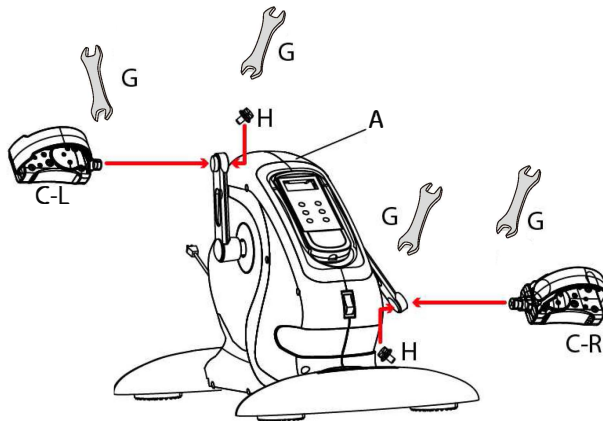

Fig. 4

1. Install the left pedal (C-L) and one screw (H) on the main body (A) as shown in Fig 4.
2. Screw well using the pedals key (G)
3. Install the right pedal (C-R) and the other screw (H) on the main body (A) according to the same procedures as step 1 and 2 above.
4. Check the pedals are secure before applying any weight

REMOTE CONTROL

Display Indicator

Speed, Time, Distance (Distance travelled km), Calories, Scan (random display).

- 1 Power On/Off
- 2 Time (Time selection button; 1-15 min)
- 3 Decrease Speed (12 settings)
- 4 Increase Speed (12 settings)
- 5 Forward/Reverse (Pedal direction)
- 6 Mode (Press to display speed, time, distance or calories)

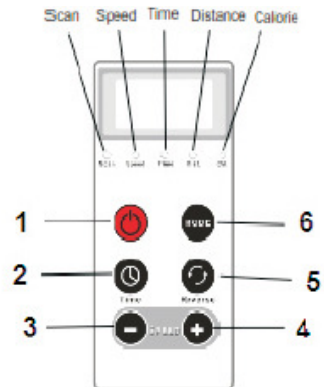

NB. For faster adjustment of Time or Speed press and hold the relevant button.

SWITCHING ON/OFF

1. Plug the socket into the wall. Switch the red button below the remote control support to position I. To switch the machine on press (1) on the remote control.
2. To switch the machine off press (1) on the remote control. Switch the red button below the remote control support to position 0 and then unplug the unit from the wall.

EXERCISES

Position 1: Seated (Lower Body)

- Use a stable, sturdy chair.
- Place the unit at a comfortable distance from the chair to avoid overstretching your legs.
- Make sure that your lower back is supported; we recommend that you place a small cushion at the base of your back.
- Sit on the chair and place your feet on the pedals.
- Remove the Remote Control from the surround on the unit. Follow the instructions for switching the unit on/off and use of the Remote Control.

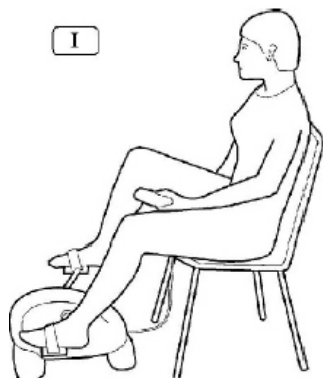

Position 2: Lying

- When lying down place the unit at a comfortable distance to avoid overstretching your legs.
- Make sure that your lower back is supported; we recommend that you place a small cushion at the base of your back.
- Place your feet on the pedals.
- Remove the Remote Control from the surround on the unit. Follow the instructions for switching the unit on/off and use of the Remote Control.
- When you finish the session, continue lying in the same position for a few moments and then get up slowly.

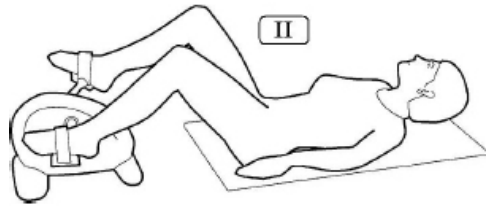

Position 3: Seated (Upper Body)

- Use a raised, fixed surface such as a table so that the unit is at chest height with the Remote Control area facing you and sit on a stable chair.
- Place the unit at a comfortable distance to avoid overstretching your arms.
- Follow the steps for Position 1 to begin the session.

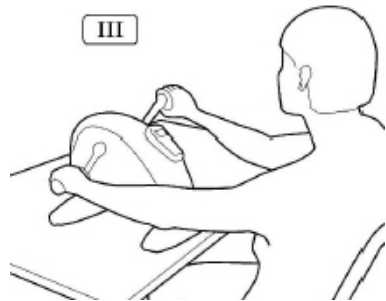

CLEANING

Switch off and unplug the unit, then clean using a non-abrasive cleaner or mild detergent with a soft cloth. Abrasive cleaners and/ or abrasive cleaning pads may seriously damage the product beyond repair and should not be used. Always ensure that you wipe dry the equipment after cleaning.

CARE & MAINTENANCE

Please make a safety check of the product at regular intervals or if you have any concerns. Pay particular attention to fastening elements and tighten if necessary. If in doubt about the safety of the unit do not use it. Please contact your supplier in the first instance for Technical Assistance and if you require spare parts to replace worn components.

PAT TESTING

When used in a workplace, this product must be safety-tested yearly by a qualified electrician (PAT Tested) in order to comply with the Electricity at Work Regulations. We recommend that it is PAT tested regularly when used in a domestic environment.

GENERAL SAFETY REQUIREMENTS

Domestic wiring must be tested periodically by a qualified electrician at least once every 10 years or at every change of occupancy.

For office and retail premises, and buildings such as village halls, the wiring must be inspected at least once every 5 years.

It is recommended that all buildings be fitted with smoke alarms (it is mandatory for new buildings).

If the mains lead is damaged, it must be replaced by the manufacturer or an authorised service centre. If the mains plug needs to be replaced, proceed as follows:

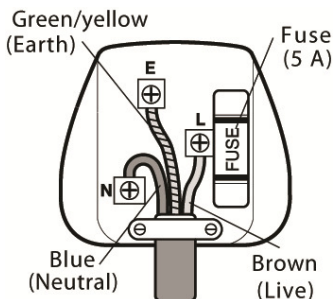

- Connect the brown wire to the terminal labelled "L".
- Connect the blue wire to the terminal labelled "N".
- Connect the green/yellow to the terminal labelled with the earth symbol or "E".
- Make sure that the cord-grip is positioned correctly (over the outer sheath of the cable) and it is fully tightened.
- If the plug is fitted with a 13 A fuse, replace it with a 5 A fuse

DISPOSAL AND RECYCLING



You must not dispose of this appliance with domestic household waste. Most local authorities have specific collection system for appliances and disposal is free of charge to the end-user.

When replacing an existing appliance with a similar new appliance your retailer may take the old appliance for disposal.

TECHNICAL SPECIFICATION

Power supply:	230 V ~
Power consumption:	70 W
Maximum Operating current:	0.3 A
Average running cost:	1p/3 hours

IMPORTANT INFORMATION

The information given in this instruction booklet must not be taken as forming part of or establishing any contractual or other commitment by Aidapt Bathrooms Limited, Aidapt (Wales) Ltd or its agents or its subsidiaries and no warranty or representation concerning the information is given.

Please exercise common sense and do not take any unnecessary risks when using this product; as the user you must accept liability for safety when using the product.

Please do not hesitate to contact the person who issued this product to you or the manufacturer (detailed below) if you have any queries concerning the assembly/use of your product.

Aidapt Bathrooms Ltd, Lancots Lane, Sutton Oak, St Helens, WA9 3EX
Telephone: +44 (0) 1744 745 020 • Fax: +44 (0) 1744 745 001 • Web: www.aidapt.co.uk
Email: accounts@aidapt.co.uk • adaptations@aidapt.co.uk • sales@aidapt.co.uk