

M48477 Vinyl with Armrests & Backrest

M53345 PU with Padded Armrests & Backrest

⚠️ General Safety Warning ⚠️

Please make sure that you read and follow these instructions carefully. Keep these instructions in a safe place for future reference.

Maximum User Weight



1. INTENDED USE

The Compact Easy Perching stool is intended to provide a comfortable, stable, seat for users who are unable to stand for long periods. The seat slopes forward to allow the user to achieve a relaxed “perching” position when sitting and also to assist the user in rising. The stool may be used in the shower, bathroom or kitchen.

2. SPECIFICATIONS:

- Powder coated steel frame
- Padded vinyl/polyurethane seat



3. SAFETY

Do not exceed the maximum user weight limit.
Inspect at regular intervals for wear and damage.
Check seat for damage or tearing.
Do not use if rubber feet are damaged.
Periodically check the legs for excess movement.
Inspect regularly to ensure Hand Nuts on all legs are fully tightened.

4. UNPACKING

Remove the packaging and check all parts carefully. Contact your supplier immediately if parts are missing or damaged and do not try and assemble.

4.1 Contents:

1. Seat/Frame x 1
2. Backrest x 1
3. Left Hand Armrest x 1
4. Right Hand Armrest x 1
5. Leg Assembly (Comprising; Leg, E- clip, Leg extension & Ferrule) x 4
6. End Cap x 6.

5. ASSEMBLY/INSTALLATION

Note: Tools are not required to assemble this product.

1. Take the leg assembly and locate it into the seat using the groove on the seat tube for alignment (See Figure 1).

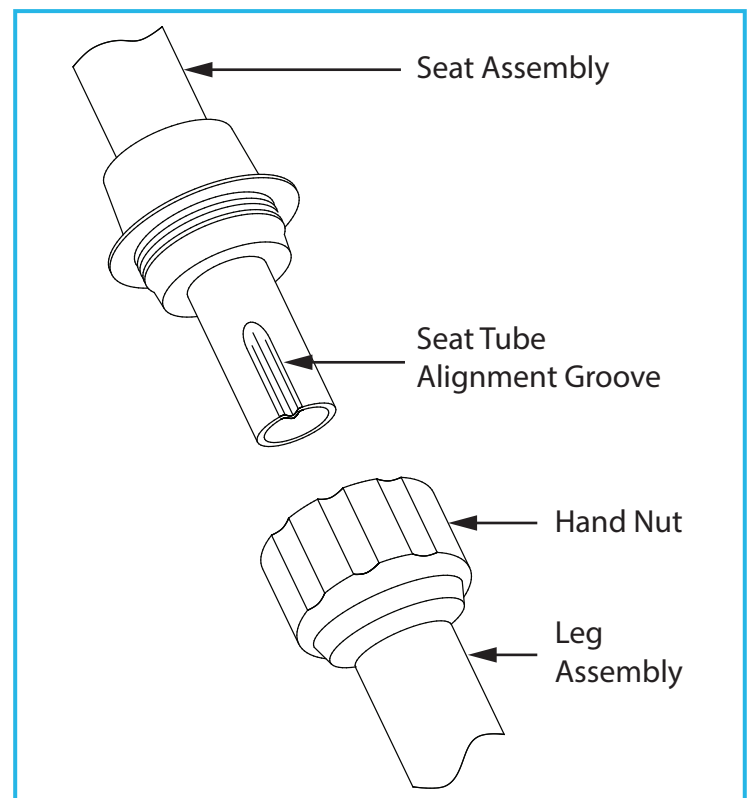

Figure 1:

2. When the leg is in position screw the plastic hand nut, on the leg, to the seat until it is hand tight, take care to align the plastic mouldings correctly before screwing tight.
3. Repeat for all four legs.
4. With the stool in an upright position fix the armrests to the product. This is done by pressing the spring clips flat to the tube, to allow the tube to enter the seat tube. Keep pushing the armrest tube into the seat until both clips "Click" into position.

Note: There is a left hand and right hand arm rest which are labelled accordingly.

5. To fix the Backrest use the same method as described for the armrests.
6. The product is now fully assembled.

Note: If required the product can be used without armrests or backrest. If this configuration is required, the ends of the tube should be sealed with the end caps supplied, to prevent water ingress.

6. IN USE

6.1 Using the Perching Stool:

Make sure the stool is placed on a level, even surface.

The stool can be used in a shower, bathroom or kitchen

6.2 Height Adjustment

To adjust the stool to the desired height, firstly remove the plastic E-clips connecting the stools' legs and leg extensions.

Slide the leg extensions to the required position ensuring that all legs are equal in height.

Replace the plastic clips ensuring that each clip is fully connected.

7. CLEANING INSTRUCTIONS.

Clean the frame regularly, using a general purpose, neutral detergent and warm water.

Please check the suitability of the cleaning products before use. Do not use abrasive cleaners or cloths as these could permanently damage the surface and invalidate any warranty.

To disinfect, wipe with a dilute bleach solution, and rinse thoroughly with fresh water.

Allow product to fully dry prior to use/storage.

8. PRODUCT DISPOSAL

This product must be thoroughly cleaned/sterilised prior to disposal.

This product is manufactured from metal and plastic and can be disposed of through Local Authority Household Waste and Recycling Centres or through Local Trade Waste Collectors.

9. PRODUCT GUARANTEE

NRS Healthcare guarantee this product for a period of 12 months, from the date of purchase, against faulty materials and workmanship.

This guarantee does not cover; abuse, misuse, interference or tampering with any part of the product.

Any guarantee issued by NRS Healthcare does not affect your statutory rights.

NRS HEALTHCARE Sherwood House, Cartwright Way, Forest Business Park
Bardon Hill, Coalville, Leicestershire, LE67 1UB, UK.

Tel: Customer Services: 0345 121 8111

Email: customerservice@nrshealthcare.co.uk

NRS Healthcare is a leading supplier of community equipment and daily living aids.
Please visit one of our websites to view our full range of products:
www.healthcarepro.co.uk or www.completecareshop.co.uk